



Multichannel Ceramic Membrane

Model Code: NPC-M-4081

General Specification	
Model Code	NPC-M-4081
Outer Diameter (O.D)	40 mm
Channel Count	81 (Circular cross-section)
Channel Inner Diameter	3.2 mm
Membrane Length	1200 mm (Maximum)
Filtration Surface Area	~0.977 m ²
Filtration Mode	Inside-out (feed in channels)
Flow Path	Axial feed, rapid permeation
Max. Operating Pressure	Up to 10 bar (material/module-dependent)
Operating Temperature	Up to 300°C (material/module-dependent)
pH Range	0–14 (material/module-dependent)
Porosity	45 ± 5%

Material & Coating Combinations		
Support Material	Available Coatings	Key Features
Silicon Carbide (SiC)	SiC (fine coating)	Excellent chemical and thermal resistance
Alumina (Al ₂ O ₃)	Zirconia (ZrO ₂)	High mechanical stability, acid-resistant
Alumina (Al ₂ O ₃)	Titania (TiO ₂)	Stable, biocompatible, suitable for bioseparations
Alumina (Al ₂ O ₃)	Silica (SiO ₂)	High water flux, chemically inert, limited alkali resistance
Mullite	Zirconia (ZrO ₂)	Optional surface: superhydrophobic/superhydrophilic
Mullite	Silica (SiO ₂)	Cost-effective, surface-tunable, moderate mechanical /thermal performance

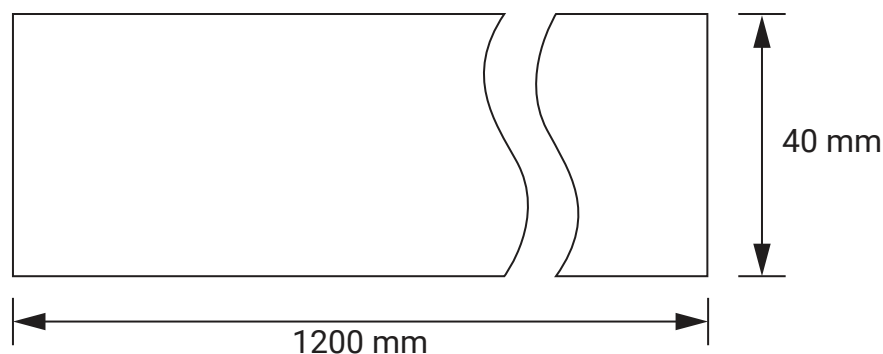
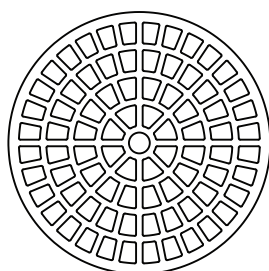



Separation Layer Options			
Membrane Type	Pore Size	Pure Water Permeability (Nominal, LMH/bar)	Typical Applications
Microfiltration (MF)	3 μ	~2200-2500 LMH	Prefiltration, Coarse solids removal, wastewater clarification
Microfiltration (MF)	1 μ	~1800-2200 LMH	Biomass separation, yeast recovery, food & beverage Prefiltration
Microfiltration (MF)	200 nm	~1200-1600 LMH	Bacteria removal, oil-water separation, suspended solids
UF/MF	100 nm	~800-1200 LMH	Cell harvesting, protein separation, microbial filtration
Ultrafiltration (UF)	50 nm	~400-800 LMH	Virus removal, enzyme separation, pharmaceutical clarification
Tight UF	20 nm	~200-400 LMH	Endotoxin removal, nanofiltration, biopolymer and viral clearance

Imp: Values represent nominal conditions at 1 bar pressure and 25°C using deionized water.

Application

- **Food & Beverage:** Clarification, microbial control, protein recovery
- **Pharma & Biotech:** Cell broth filtration, enzyme separation
- **Petrochemical:** Oil-water separation, catalyst recovery
- **Water Treatment:** MBR polishing, RO pretreatment

Advantages

- Exceptional surface area ($\sim 0.977 \text{ m}^2$) for high-capacity applications
- High throughput with 81 optimized 3.2 mm channels
- Superior chemical and thermal resistance for demanding environments
- Fully compatible with CIP and backflush procedures
- Robust ceramic structure for long service life
- Scalable and modular—ideal for both new installations and retrofits

